

DHR3

NOTE: Set up for this sensor should be performed by an AAADM-certified installer.

Section 1

General Description

The DHR3 is a combination microwave/infrared sensor providing both motion detection and presence detection in one microprocessor controlled sensor for all types of automatic doors.



- Wide and narrow pattern width of the sensor is adjustable.
- Pattern depth and width are adjustable using mounting height, dip switches, pattern width and pattern angle adjustments.
- Frequency is selectable in four channels
- Self-Diagnostic means the sensor continuously monitors itself.
- Snow Mode Switch ensures against false operation caused by snow, insects, etc.
- Microprocessor provides programmable Presence Timer (2 sec., 30 sec., 60 sec., or infinity).

Section 2

Parts Identification

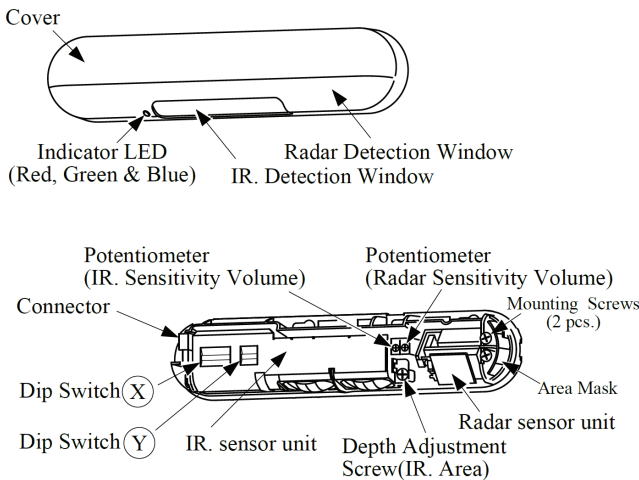

Accessories

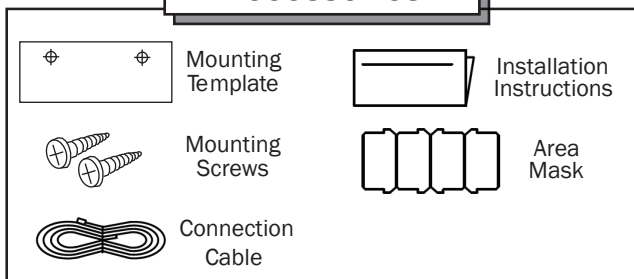

Section 3

Mounting Information

1. Do not mount higher than 10.5 ft. (3.2m).
2. Mount within 1.97" (50mm) from the bottom of the door engine cover.
3. Do not leave any objects which may move in the detection pattern.
4. Do not mount in a humid or steamy environment.
5. Do not mount where rain or snow will fall directly on unit.
6. Do not mount where snow or water will accumulate on floor if possible.
7. Do not mount in a place where reflection of sunlight will shine on unit.
8. Use different frequency settings for sensor in close proximity.
9. The radar part of the DHR3 sensor may be negatively influenced by metal close to or in the detection field.

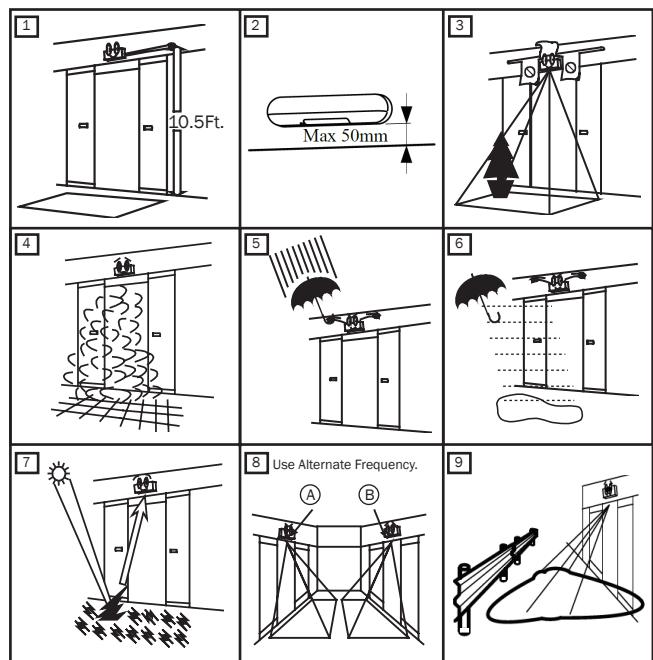

To maximize the effectiveness of doorway detection, install the DHR3 outside and inside as shown below.

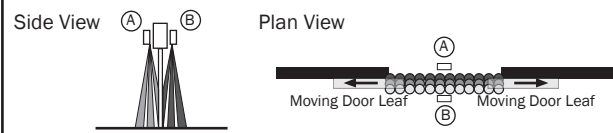

DHR3

Section 4

Mounting and Wiring

- Using the mounting template provided, drill mounting and wire holes.

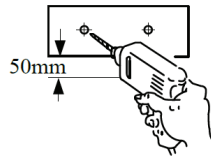

- Remove cover of unit.

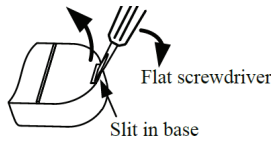

- Fasten unit with mounting screws provided.

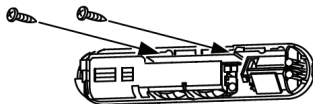

- Wiring to a door controller that **can** test the sensor.

NOTE: "Test Input" dip switch setting (Y) 6 to "ON". Refer to Section 5: Dip Switch Settings.

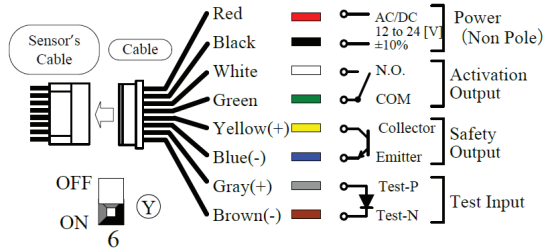

- Wiring to a door controller that **cannot** test the sensor.

NOTE: "Test Input" dip switch setting (Y) 6 to "OFF". Refer to Section 5: Dip Switch Settings.

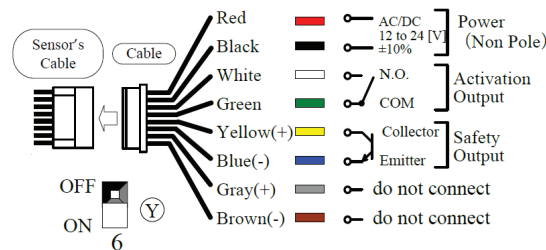

- House connectors in the space provided.

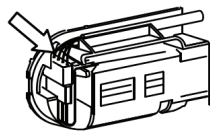

- Replace cover.



Removing cover after installation:

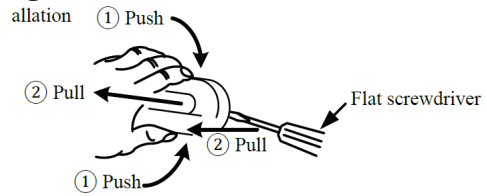

Section 5

Dip Switch Settings

Dip Switch X

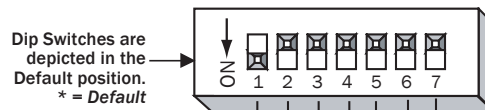

IR Presence Timer	IR Frequency	Monitor Mode	Safety Relay Output	Reflection Diagnostics
2 Sec <input type="checkbox"/>	*A <input type="checkbox"/>	*Normal <input type="checkbox"/>	*N.O. <input type="checkbox"/>	*Normal <input type="checkbox"/>
*30 Sec <input type="checkbox"/>	B <input type="checkbox"/>	<input type="checkbox"/>	*N.C. <input type="checkbox"/>	Transmitter Receiver IR Spot
60 Sec <input type="checkbox"/>	C <input type="checkbox"/>	Snow <input type="checkbox"/>	<input type="checkbox"/>	Low Ref. <input type="checkbox"/>
∞ Sec <input type="checkbox"/>	D <input type="checkbox"/>	<input type="checkbox"/>	<input type="checkbox"/>	Transmitter Receiver IR Spot <input type="checkbox"/>
① ②	③ ④	⑤	⑥	⑦

- IR Presence Timer:** The sensor will detect a stationary object for the time period set by the Presence Timer for the inner 3 rows. The timer will reset and begin if **any** movement is detected.
- Frequency:** When more than two sensors are used in close proximity to each other, to prevent interference use alternate frequency settings.
- Monitor Mode:** A Snow Mode is available. Snow Mode should only be used in environments with heavy snowfall or other extreme conditions.
- Safety Relay Output:** Refer to Section 9: Timing Chart of Events for full details on Safety Output.
- Reflection Diagnostics:** A low reflected infrared signal is indicated by a slow flashing Red/Green LED. To ignore this low reflection error state, set this dip switch to "Low Reflection" (ON).

DHR3

Dip Switch Y

Dip Switches are depicted in the Default position.
* = Default

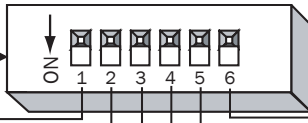

Direction Detection Radar	Activation Relay Output	Activation Relay Output Config.	Door Hold	Doorway Learn	Test Input Setting from Door Controller
*OFF <input type="checkbox"/>	*N.O. <input type="checkbox"/>	*OFF <input type="checkbox"/>	*Auto <input type="checkbox"/>	*OFF <input type="checkbox"/>	*OFF <input type="checkbox"/>
ON <input type="checkbox"/>	N.C. <input type="checkbox"/>	RADAR = IR rows 2+3 <input type="checkbox"/>	Open <input type="checkbox"/>	ON <input type="checkbox"/>	ON <input type="checkbox"/>
①	②	③	④	⑤	⑥

- Direction Detection Radar:** When set to ON, pedestrians moving away from the sensor will not be detected.
- Activation Relay Output:** Refer to Section 9: Timing Chart of Events for full details on Activation Output.
- Activation Relay Output Configuration:** Choose how relay output is configured.
- Door Hold:** Switch to OPEN to hold the door in the open position.
- Doorway Learn:** Allows the 1st row of detection to be focused inside the door close area without detecting the door movement.
NOTE: When "Doorway Learn" is turned ON, the sensitivity level of the 1st row of detection is at maximum only when the outer rows of detection are activated.
- Test Input Setting from Door Controller:** When connected to a door controller without a TEST input, set to "OFF". When connected to a door controller with a TEST input, set to "ON". Refer to Section 9: Timing Chart of Events for details.

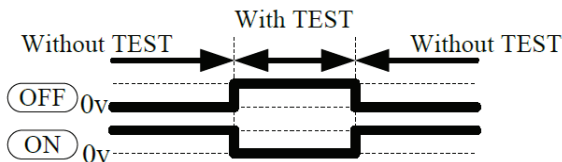

Section 6

Detection Area

Detection Area Depth Adjustment: IR (Inner 3 Rows)

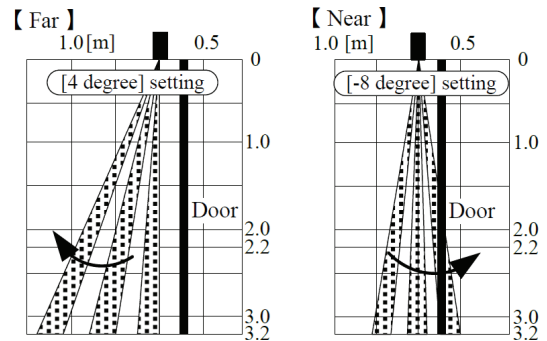
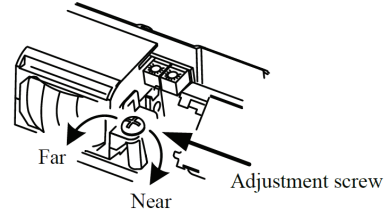

Detection Area Width Adjustment: IR (Inner 3 Rows).

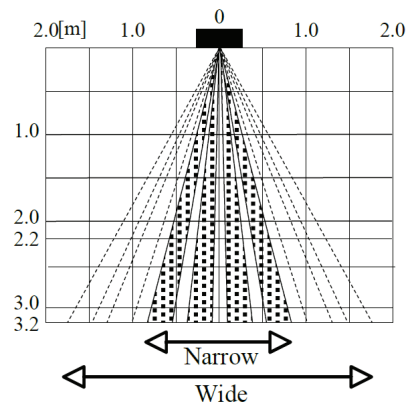
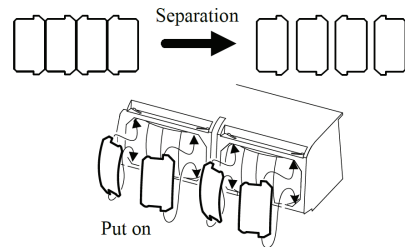

DHR3

Detection Area Depth Adjustment: Radar (Outer).

- Detection area varies depending on walking speed.
- Adjustment possible in 3° steps as illustrated.

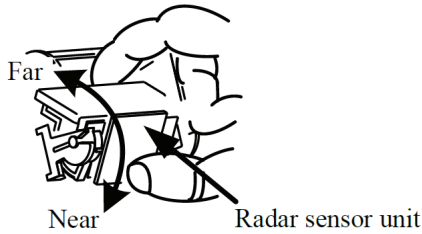

Installation height 7.2' (2.2m) & Sensitivity set to "High".

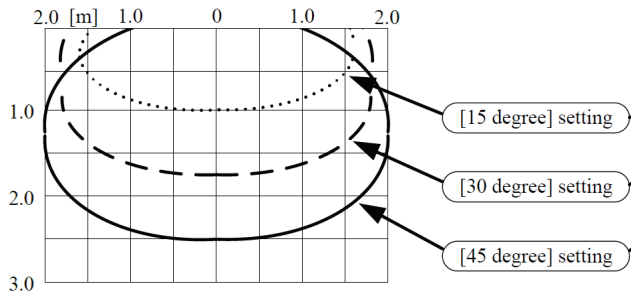

Installation height 7.2' (2.2m) & Sensitivity set to "Low".

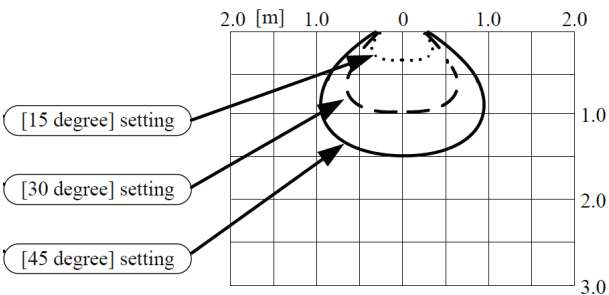

CAUTION: The detection areas shown above represent the actual position of the infrared and radar patterns. The actual detection area will vary depending upon the individual sensor installation, sensor settings and objects being detected.

Section 7

Power & "Doorway Learn" Setting

BEFORE APPLYING POWER, READ AND FOLLOW THESE INSTRUCTIONS:

When power is applied, the sensor will read and store the environmental optical parameters. This is necessary for Presence Detection to work properly.

1. CLEAR THE AREA OF ANY UNNECESSARY OBJECTS.
2. Apply POWER.

3. Vacate the Detection Pattern immediately. While the sensor sees ANY moving objects in its DETECTION PATTERN, it will not proceed to the following step.
4. DO NOT enter DETECTION PATTERN for 10 seconds (Presence Detection Setting).
5. TEST the presence feature, especially near the door.

When carrying out the following work, TURN OFF THE POWER:

1. When the floor conditions change.
2. Adjusting pattern or sensitivity.

"DOORWAY LEARN" is OFF

(Ref. Sec. 5-Dip Switch Settings)

- Upon power ON, the solid Green LED turns on indicating that the sensor is in standby mode and ready to detect.

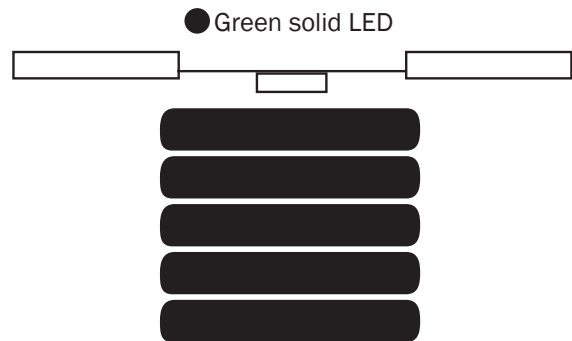

Presence Detection: It takes 10 seconds after the sensor powers up for presence detection to be initiated on all rows of detection. If someone enters the detection area before 10 seconds has elapsed, the sensor will continue to initialize until after 5 seconds with no motion being detected.

"DOORWAY LEARN" is ON

(Ref. Sec. 5-Dip Switch Settings)

- Upon power ON, the Red LED indicates a door open relay output to begin the "Doorway Learn" process.

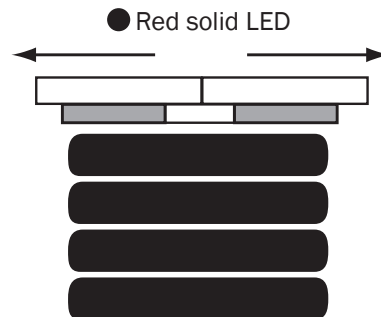

DHR3

- Green LED blinks for 37 seconds while the “Doorway Learn” process is carried out. Door opens/closes.

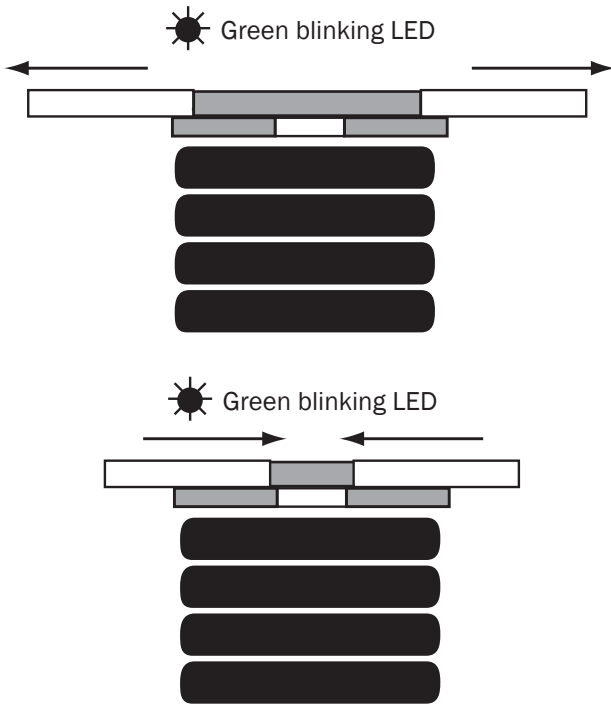

- After the “Doorway Learn” process is completed, sensor is in standby mode.

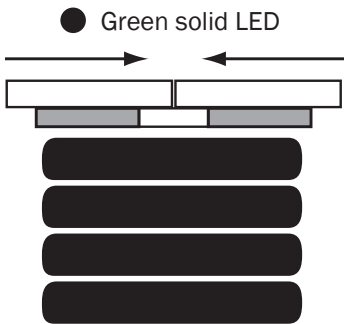

Presence Detection: During the “Doorway Learn” process, the outer 3 rows of detection on the DHR3 sensor switch from motion detection to presence detection 10 seconds after power ON. The inner “Doorway Learn” row of detection will switch from motion to presence detection after the “Doorway Learn” process is complete.

“Doorway Learn” Failure & Recovery: If a person enters the detection area during the “Doorway Learn” process, it may not be successfully completed. In this case, the sensor will carry out the “Doorway Learn” process on

door activation caused by a person in order to build an accurate image of the door open and door close position.

NOTE: When “Doorway Learn” is turned ON, the sensitivity level of the inner row of detection is at maximum ONLY when the outer rows of detection are activated.



CAUTION: If you change dip switch setting or sensitivity volume, the sensor will be reset. During resetting, indicator LED is blinking with orange color. Keep away from detection area. After resetting, the sensor becomes the same state as it is turned Power-on.

In case the product is used as a supplementary sensor: Set the detection area of the 1st row away from the door.

Section 8

Verification of Operation

After installation is complete, walk test the detection zone. If the detection zone is not as expected, adjust the detection area as referred to in Section 6.

If the detection area is still not as expected then the sensor sensitivity can be increased by turning the potentiometer clockwise. When the sensor detects even though there is nothing in the detection zone, the unit’s sensitivity can be decreased by turning the potentiometer counter-clockwise.

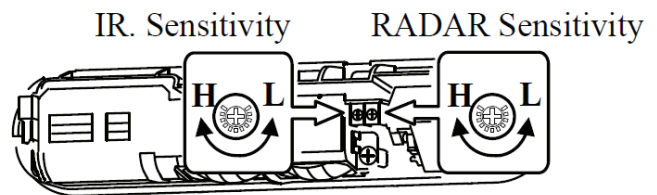

DHR3

Section 9

Timing Chart of Events

After installation is complete, walk test the detection zone. If the detection zone is not as expected, adjust the detection area as referred to in Section 6.

Safety Output/Test Input

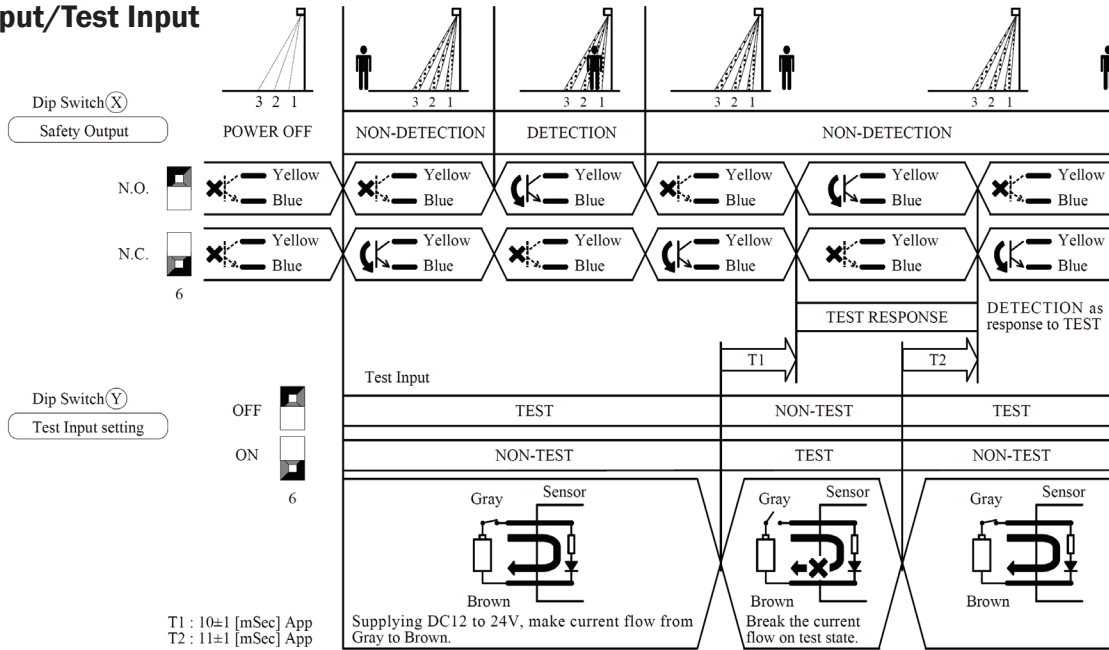

Activation Output

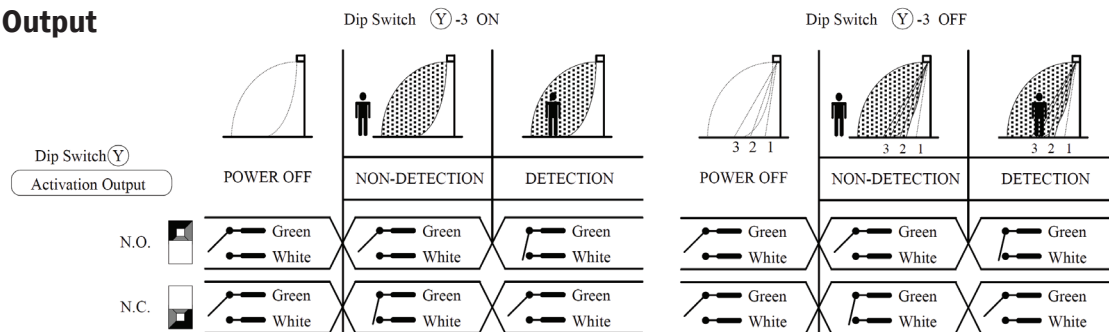

Section 10

Door Maintenance Work

When carrying out door maintenance work with power applied to the sensor, on door controllers that are wired to "TEST" the sensor, ensure to set the dip switches as shown here:

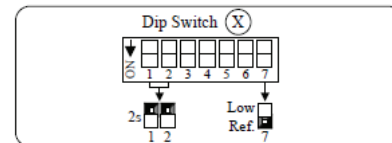

NOTE: Return dip switch settings to original state when maintenance work is complete.

DHR3

Section 11

Self Monitoring

When the sensor has an internal sensor error, the door will remain open and the Green/Red LED blinks alternately. The frequency of flashing indicates the type of problem as explained below:

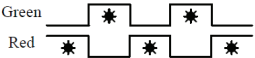
Flash Frequency	LED	CAUSE
Fast		Please replace sensor.
Slow		Confirm sensitivity potentiometer is set to maximum and repower the sensor. If the error persists, set Dip Switch (X)7 to "Low Reflection".

*******EXTREMELY IMPORTANT*******

After final set-up, test unit(s) completely to ensure that proper coverage has been achieved (width, depth and location of the pattern must be tested).

After the installation and operational check of the system:

1. Place the proper labels on the door per ANSI/BHMA A156.10.
2. Instruct the owner of the door system operation and how to test it. This should be checked on a daily basis.
3. Instruct the owner on what to do if the door or any of its components become damaged.
4. Strongly recommend to the owner that the complete entry be inspected twice a year as part of the service agreement.

Section 12

Troubleshooting

PROBLEM 1: Door does not open

LED STATUS: Off

CAUSE 1: Sensor Connector
SOLUTION 1: Tighten connector or reconnect

CAUSE 2: Power Supply
SOLUTION 2: Check that the power supply is properly connected and 12V to 24V AC or DC

CAUSE 3: Sensor Wiring
SOLUTION 3: Double check sensor wiring.

PROBLEM 2: Door operates by itself (ghosting)
LED STATUS: Door Opens=RED or BLUE, Door Closes=Green

CAUSE 1: There is an object moving in the detection area
SOLUTION 1: Remove the moving object from detection area

CAUSE 2: Sensitivity too high
SOLUTION 2: Turn down sensitivity

CAUSE 3: Dust, frost or water droplet on the sensor lens
SOLUTION 3: Wipe sensor lens with clean cloth and install a weather cover if necessary

CAUSE 4: Detection area overlaps with that of another sensor
SOLUTION 4: Ensure different frequency setting for each sensor

CAUSE 5: Detection of falling snow, insects, leaves, etc.
SOLUTION 5: Adjust the Monitor Mode

PROBLEM 3: When door opens or closes, LED ORANGE
LED STATUS: ORANGE

CAUSE 1: Detection row "ROW 1" ("ROW 2" when "Doorway Learn" is turned ON) is focused too close to the door
SOLUTION 1: Adjust detection depth of rows away from the door

PROBLEM 4: Door opens and remains in the open position
LED STATUS: RED

CAUSE 1: Detection area changed, while infinity presence timer setting is in use
SOLUTION 1: Repower the sensor or change the presence timer settings to 30 or 60 seconds

CAUSE 2: Incorrect Sensor Wiring
SOLUTION 2: Double check sensor wiring

CAUSE 3: Reflected Signal Saturation
SOLUTION 3: Remove highly reflective objects from the detection area, or lower the sensor sensitivity

DHR3

Microwave/Infrared Motion & Presence Detector for Automatic Doors

INSTALLATION INSTRUCTIONS

LED STATUS: BLUE

- CAUSE 1: Moving objects in radar area
SOLUTION 1: Remove moving objects from detection area

LED STATUS: GREEN/RED FAST FLASH

- CAUSE 1: Internal Sensor Error
SOLUTION 1: Replace the sensor

LED STATUS: GREEN/RED SLOW FLASH

- CAUSE 1: Reflection of the transmitted infrared signal from the floor is too low
SOLUTION 1: Increase sensor sensitivity or change the "Reflection Diagnostics" Dip Switch (X)7 from "Normal" to "Low Ref"

LED STATUS: ORANGE BLINKING (Slow)

- CAUSE 1: Door Hold (Dip switch (Y)4 set to Open)
SOLUTION 1: Turn "Door Hold" Dip Switch (Y)4 to Auto

Section 13

Technical Data

- Model..... DHR3
Detection Method..... Doppler Shift Radar & Active Infrared Reflection
Max. Installed Height..... 10.5 ft. (3.2m)
Power Supply..... 12 to 24 V AC or DC \pm 10%
Power Consumption..... AC24V-2.5VA, AC12V-2.5VA
DC24V-80mA, DC12V-150mA

INFRARED SENSOR

- Detection Method..... Active Infrared Reflection
Output Holding Time..... 0.5 seconds
Response Time..... 0.1 - 0.2 seconds
Presence Timer..... 2 sec., 30 sec., 60 sec., or infinity (∞)
Output Contact..... 7.5mA Max (Resistor Load)
55V DC Max Voltage
50mA Max. Current

MICROWAVE SENSOR

- Detection Method..... Doppler Shift Radar
Operating Frequency..... 24.15 GHz
Output Holding Time..... 1.5 seconds
Response Time..... 0.1 - 0.2 seconds
LED Indication..... GREEN = Standby
GREEN BLINKING - Doorway Learning (when dip switch (Y)5 is ON)

- BLUE = Radar Detecting
RED = IR Detecting / Radar and IR Detecting
ORANGE = Detection row "ROW 1" ("ROW 2" when "Doorway Learn" is turned ON) is detecting door movement
ORANGE BLINKING (Fast) = Indicates a change of dip switch settings
ORANGE BLINKING (Slow) = Door Hold is turned ON (When dip switch Y 4 is ON)
GREEN/RED BLINKING (Fast) = Internal Sensor Error
GREEN/RED BLINKING (Slow) = Reflected infrared signal from the floor is very low

- Test Input..... 6mA @ 24V DC
IP Rating..... IP54
Temperature Range..... -4 °F to 140 °F (-20 °C to 60 °C)
Operating Humidity..... Below 80%
Weight..... 0.56 lbs. (0.26kg)
Color..... Black, Silver
Accessories..... Cable
Mounting Screws (2 pcs.)
Mounting Template
Installation Instructions

Section 14

External Dimensions

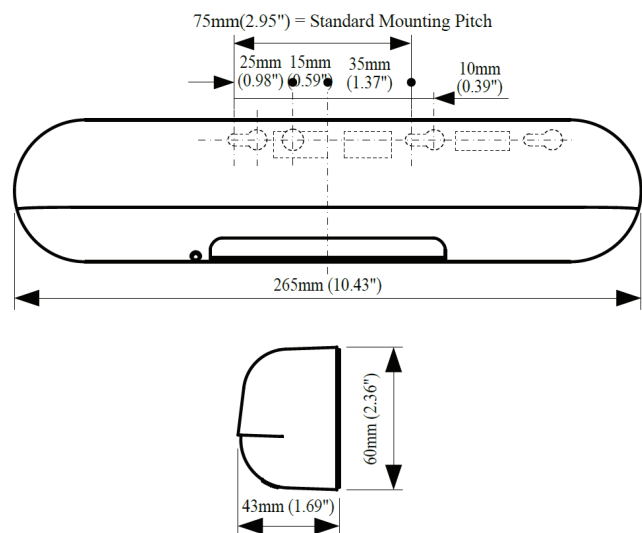

DHR3

Section 15

Warranty

MS SEDCO guarantees this product to be free from manufacturing defects for 3 years from date of installation. Unless MS SEDCO is notified of the date of installation, the warranty will be in effect for 3 years from the date of shipment from our factory. If, during the first 3 years, our motion detector or support device fails to operate and has not been tampered with or abused, the unit can be returned prepaid to factory and it will be repaired free of charge. After 3 years, the unit will be repaired for a nominal service charge. **This limited warranty is in lieu of all other warranties expressed or implied, including any implied warranty of merchantability, and no representative or person is authorized to assume for MS SEDCO any other liability in connection with the sale of our products. All warranties are limited to the duration of this written warranty. In no event shall MS SEDCO be liable for any special, incidental, consequential or other damages arising from any claimed breach of warranty as to its products or services.**