

Product Name

SAM
Secondary Activation Module

Contact Information

MS SEDCO
7898 Zionsville Road
Indianapolis, IN 46268
Phone: (317) 842-2545
www.mssedco.com

Product Description

BASIC USE

The SAM is a microprocessor based secondary activation timing module designed to meet the ANSI A156.10 2005 requirements that knowing act power operated pedestrian swing doors (typically hospital corridor doors) include an approach sensor on the non-swing side of the door that is only active while the door is open or in its closing cycle.

The SAM is equipped with Intelligent Door Position™ monitoring circuitry that will automatically identify a swing door's open and closed positions and determine its closing time. The SAM then controls the push plate wall switch (knowing act), approach sensor (secondary activation) and overhead safety sensor. The proprietary software

monitors the door's position and controls when to turn on and off the approach sensor after the push plate is activated while simultaneously monitoring the overhead safety sensor and locking out its signal during the door's closing cycle. By providing single source control for the push plate, secondary activation sensor and overhead safety sensor, the SAM streamlines installations by eliminating products and speeds up installation time by ending "trial and error" manual adjustments.

The SAM can also be used on operators not equipped with a safety circuit providing a more economical upgrade alternative to replacing expensive operator controls.

The SAM is for use on electromechanical operators only.

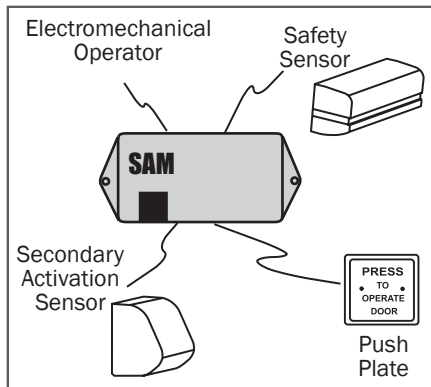

Technical Data SPECIFICATIONS

Model	SAM
Power	12 to 24 V AC or DC
Power Consumption	<1W
Output Contact	Form C, Rated At 3 Amps
Temperature	-22° F to 158° F (-30° C to 70° C)
Color	Flat Black
Enclosure	ABS Plastic
Weight	0.25 lb.
Physical Size	4 3/4"L x 2 1/4"W x 3/4"H

APPLICABLE STANDARDS

American National Standards Institute (ANSI) - Building Hardware Manufacturers Association (BHMA) - ANSI/BHMA A156.10 & A156.19.

Availability & Cost

AVAILABILITY

Available internationally from manufacturer's authorized distributors; contact MS SEDCO for the location of nearest distributor.

COST

Cost information on MS SEDCO products is available from the manufacturer's authorized distributor.



Secondary Activation Module



ENGINEERED FOR MOTION

Warranty

MS SEDCO, Inc. guarantees this product to be free from manufacturing defects for one year from date of installation. Unless MS SEDCO is notified of the date of installation, the warranty will be in effect for one year from the date of shipment from our factory. If, during the first year, this product fails to operate and has not been tampered with or abused, the unit can be returned prepaid to the factory and be repaired free of charge. After one year, the unit will be repaired for a nominal service charge. **Limited warranty is in lieu of all other warranties, expressed or implied, including any implied warrantability of merchantability.** No representative or person is authorized to assume for MS SEDCO any other liability in connection with the sale of our products. All warranties are limited to the duration of this written limited warranty. In no event shall MS SEDCO be liable for any special, incidental, consequential or other damage arising from any unclaimed breach of warranty as to its products or services.

personnel offer design assistance and technical support. Local distributors are also available to assist in selecting appropriate devices for specific uses and to provide onsite installation.

DIMENSIONS

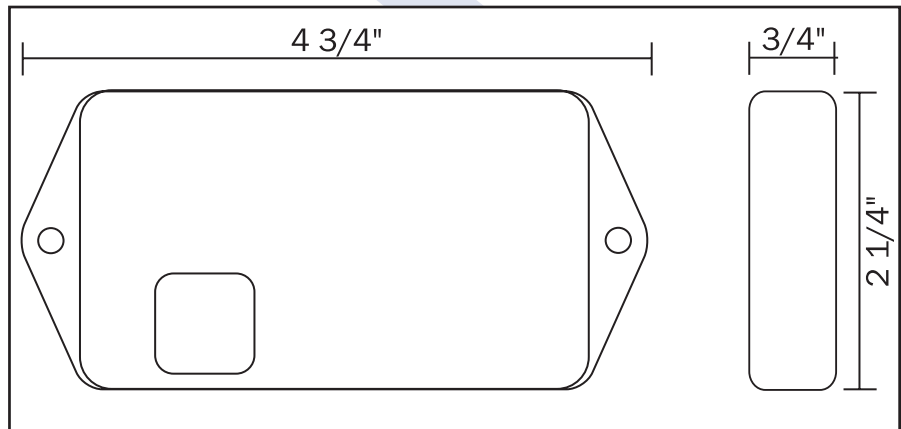

Maintenance

MS SEDCO recommends that all maintenance and adjustments be performed by an AAADM Certified Technician.

Technical Services

MS SEDCO's staff of factory trained sales and service