

Section 1

General Description

The ClearPath Spectrum Wireless System is comprised of two devices; a Coordinator (S-COR) that functions in a similar role as traditional wireless system receivers, and a Transceiver (S-TRX) that functions in a similar role as traditional wireless transmitters, but this is where the similarities end. The Spectrum Wireless System provides several industry firsts:

- Digital two-way communication allows for greater security and ensures successful signal transmission between devices.
- LCD screen (S-COR) for quick and easy programming.
- Upon switch activation, the Transceivers communicate valuable information that is displayed on the LCD screen including: device ID, signal strength and battery monitoring.
- Pairing of multiple Transceivers with Coordinators.
- Two built-in outputs (S-COR).
- 3 year battery life (S-TRX).

ClearPath Spectrum products operate at 2.4 GHz, making the wave length more than 5 times shorter than commonly-used frequencies. Shorter waves pass through cracks and barriers easier, and transceivers will continue to attempt to contact the Coordinator until it receives an acknowledgement.

OPTIONS:

- S-TRX** = Spectrum Transceiver with 1020 Square Mounting Box
- S-TRX-R4** = Spectrum Transceiver with 1025 Round Mounting Box
- S-TRX-R6** = Spectrum Transceiver with 1030 Round Mounting Box
- S-TRX-J** = Spectrum Transceiver with 1010 Jamb Mounting Box

Section 2

Basic Installation

- 1) Remove the 1/4-20 screw located in the bottom of the Frame and separate the Back Plate from the frame. Secure the back plate in its intended location with at least 2 screws (See Fig.1).



WARNING: Mounting screws must be flush with the Back Plate to ensure proper assembly.

- 2) Install CR2032 Battery (Energizer Recommended).

FIGURE 1

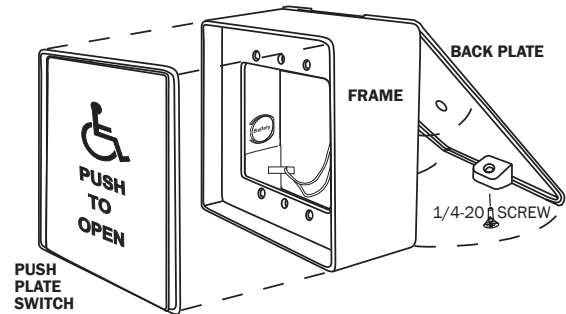

(Front View: S-TRX Shown)

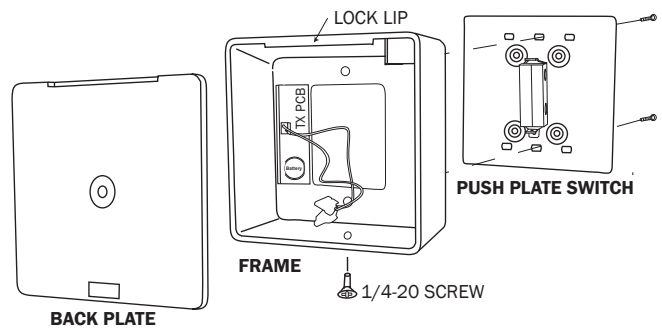

(Rear View: S-TRX Shown)

- 3) Take the Frame and Transceiver assembly to the Coordinator location and place the Coordinator into pairing mode (see S-COR Install Manual).



NOTE: The easiest way to confirm successful pairing of Transceivers (S-TRX) is to first connect the Coordinator to the operator control so that it is ready for programming and then pair all Transceivers **at the Coordinator location**. When the pairing button on the Transceiver is pressed, the pairing confirmation message "Device Paired" is displayed on the Coordinator LCD screen.

- 4) Press PAIR Button on the Transceiver PCB once Coordinator is ready (See Fig. 2).

FIGURE 2
Transceiver Circuit Board

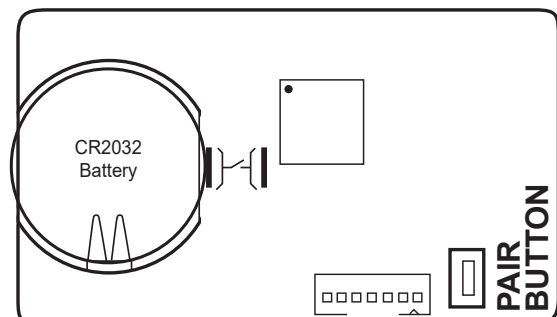

- 5) The Coordinator LCD screen will display "Device Paired" upon successful pairing.
- 6) Attach the Push Plate Switch (purchased separately) to the Mounting Box Frame with the 6-32 screws provided with the Push Plate switch (See Fig. 1).
- 7) Plug the 2-lead Transceiver wire harness onto the COM (Common) and N.O. (Normally Open) contacts located on the Push Plate Switch (See Fig. 3).

FIGURE 3
Press Plate Micro-Switch

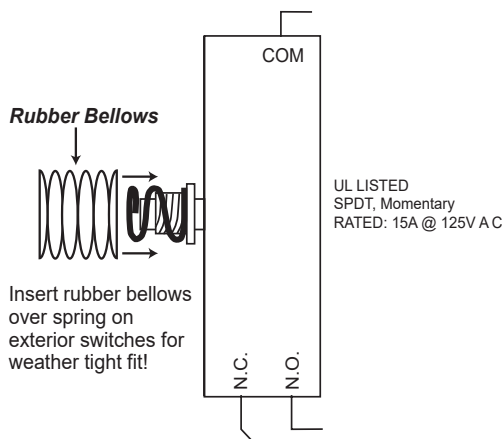

- 8) Attach the Mounting Box Frame to the Back Plate already mounted in its intended location (step 1) by placing the lock lip of the Frame over the top of the Back Plate, pushing it down in a hinge-like motion (See Fig. 1).
- 9) Secure the Frame to its Back Plate at the underside with the 1/4-20 screw supplied (See Fig. 1).



NOTICE: This device complies with Part 15 of the FCC rules. Operation of this device is subject to the following two conditions: 1) This device may not cause harmful interference and 2) This device must accept any interference received, including interference that may cause undesired operation. Any changes or modifications not expressly approved by MS SEDCO could void the user's authority to operate this equipment.

Section 3

Operational Mode

In operational mode, whenever a Transceiver is activated, the Coordinator screen will display the following information: ID, battery status and signal transmission strength (See Fig. 4).

FIGURE 4
S-COR Screen when S-TRX is Activated



Transceiver ID:	4 digit automatically assigned
Signal Strength:	**** Optimal *** Good ** OK * Weak
Battery Status:	Battery OK Replace Battery

Section 4

Maintenance

For best results, change the battery every 3 years, or as needed. To remove the current battery, use a small flat-head screwdriver, approaching from the wire harness socket side of the pcb as shown (See Fig. 5).

FIGURE 5
Transceiver Circuit Board

