



Section 1

General Description

The RLM is a Relay Lock Out Safety Module for automatic swing doors. The RLM will monitor the door open to door closed positions and provide for the control of the approach sensor, overhead presence sensor and safety beams. All devices connected to the RLM are monitored so that the activate circuit of the door operator is enabled at the appropriate time to ensure safe operation. The RLM can also be used to provide a safety circuit to low energy operators that do not have this capability.

The RLM meets ANSI A156.10 2005 requirements for swing door operators when properly installed with the appropriate sensors.

Section 2

Basic Installation

The RLM consists of a control module (RLM-CM) and a set of wet contact safety beams (RLM-SB) that wire directly into the control module. In addition, dry contact safety beams, such as the MS SEDCO GD11S can also be used, however there are wiring differences. The wiring diagrams provided in this manual are for the RLM-SB safety beams.

- 1. Mount the RLM-CM control module in the door operator housing.
2. With power off, make all necessary wire connections to the wiring harnesses. Refer to Figures 1 & 2 for wiring illustrations.
3. Install resistor (Fig. 1) ONLY if the motor voltage exceeds 50V AC.
4. Mount the RLM-SB safety beams to the end of the rails on the swing side of the door beyond the leading edge of the door in its open position.
5. Run the cable from each safety beam back to the RLM-CM control module. Cut the cable to length and attach the wires to the proper control module wiring harness. Refer to Figures 1 & 2 for wiring illustrations.

The RLM layout and wiring connections are shown in Figures 1 & 2

- 6. After successfully making all wiring connections, plug both wire harnesses into the RLM-CM control module. Refer to Figure 3 for operating display explanations and programming instructions.

The RLM programming instructions are shown in Figure 3



NOTICE—DRY CONTACT SAFETY BEAMS:

If using dry contact safety beams, remember these changes:

- 1. Power the safety beams directly off the transformer that is used for the RLM.
2. The White/Red striped wire is not used and should be taped off.

- 3. The White/Brown striped wire is not used and should be taped off.
4. The White/Gray striped wire is only used for the presence sensor.
5. The Orange and White/Green striped wires of the RLM go to the N.O. and COM dry contacts of the safety beams.



NOTICE: These instructions are provided for your convenience. Please verify your installation is in compliance with all applicable standards upon completing installation of this product.



NOTICE: The RLM works with both electromechanical and electrohydraulic operators. Confirm which type of operator is being used before installing the RLM-CM. Follow the proper wiring diagram (2a or 2b) for your operator. For technical assistance contact us at 317-842-2545.

Section 3

Technical Data

Table with 2 columns: Parameter and Value. Includes Model (RLM), Input Power (12-24V AC or DC), Power Consumption (<1W), Output Contacts (Form C), Temperature Rating (-22°F to 158°F), Weight (<0.25 lbs), and Physical Size (RLM: 4.75"L x 2.125"W x 0.75"H; Safety Beams: 2.875"L x 1.75"W x 1"H).

Section 4

Warranty

MS SEDCO guarantees this product to be free from manufacturing defects for 1 year from date of installation. Unless MS SEDCO is notified of the date of installation, the warranty will be in effect for 1 year from the date of shipment from our factory. If, during the first year, this device fails to operate and has not been tampered with or abused, the unit can be returned prepaid to factory and it will be repaired free of charge. After 1 year, the unit will be repaired for a nominal service charge. This limited warranty is in lieu of all other warranties expressed or implied, including any implied warranty of merchantability, and no representative or person is authorized to assume for MS SEDCO any other liability in connection with the sale of our products. All warranties are limited to the duration of this written warranty. In no event shall MS SEDCO be liable for any special, incidental, consequential or other damages arising from any claimed breach of warranty as to its products or services.

Questions? Call us toll-free at 1-317-842-2545 or visit us online at www.mssedco.com.



FIGURE 1—RLM Layout & Wiring Connections

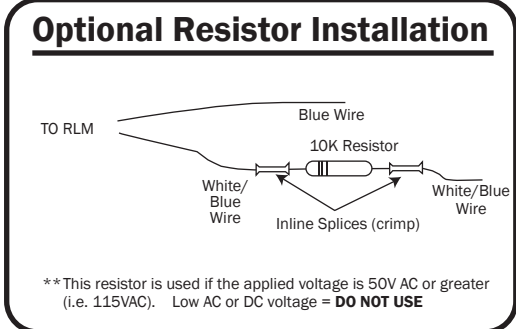
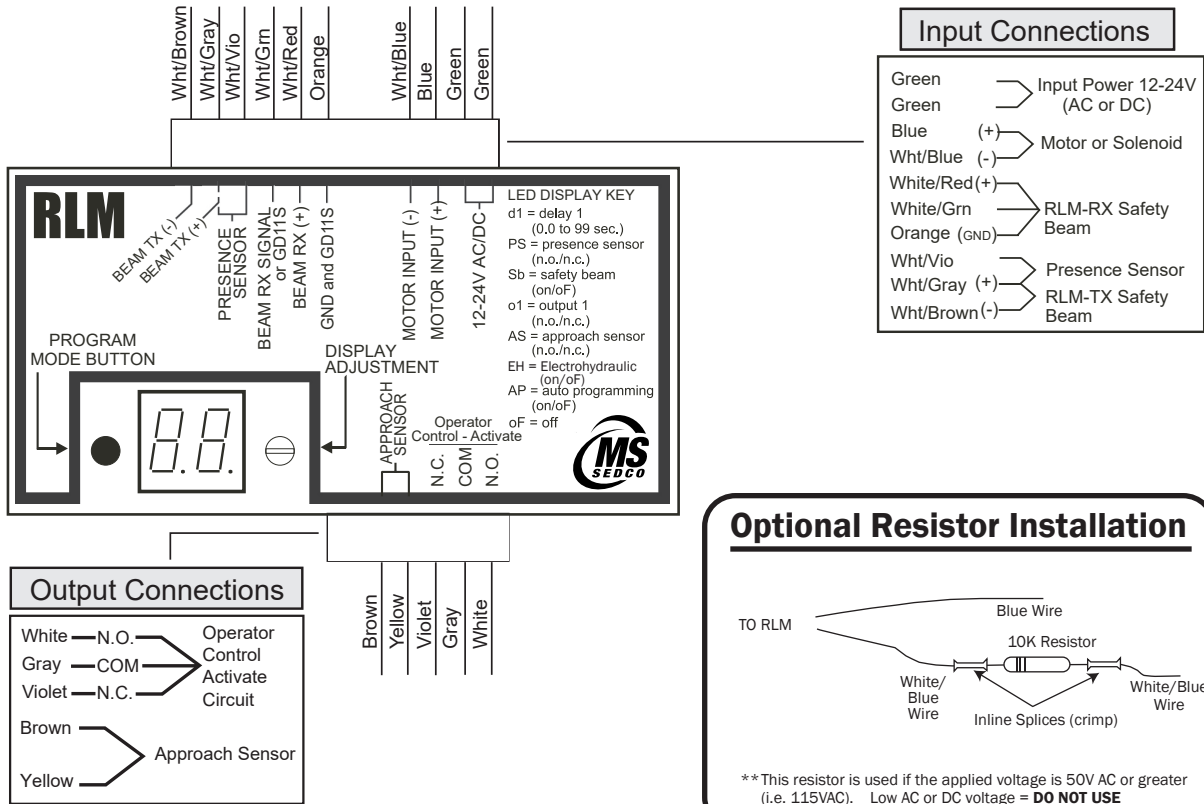

FIGURE 2a—RLM Wiring Diagram

Operator Type: Electromechanical

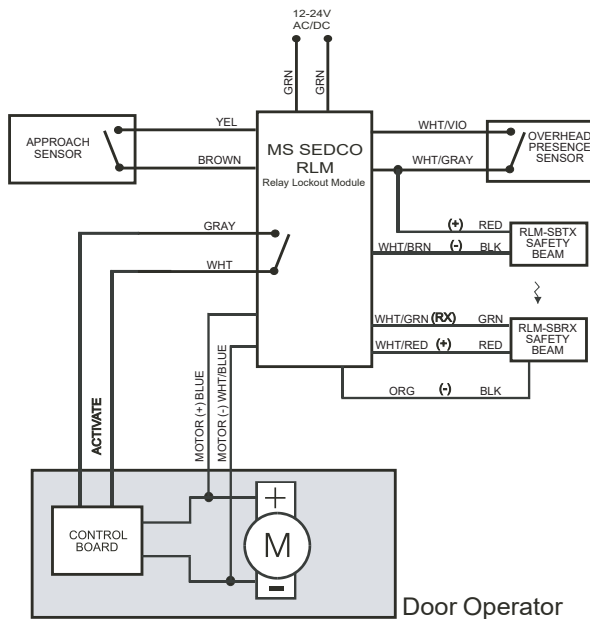

FIGURE 2b—RLM Wiring Diagram

Operator Type: Electrohydraulic with or without Solenoid

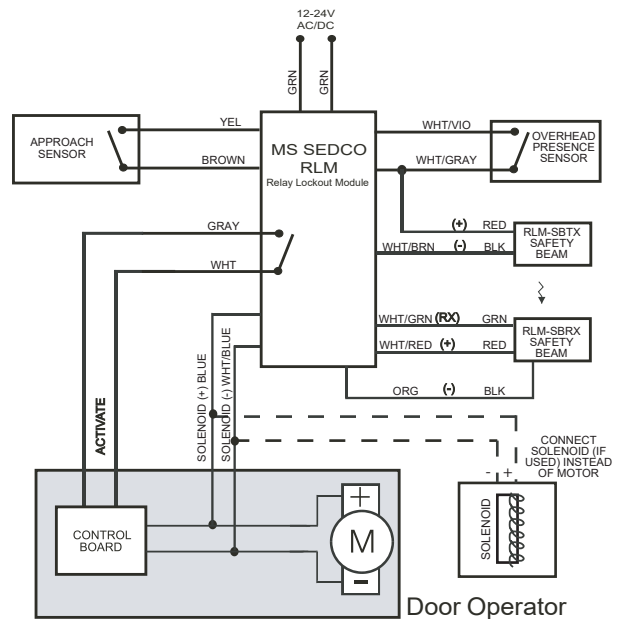
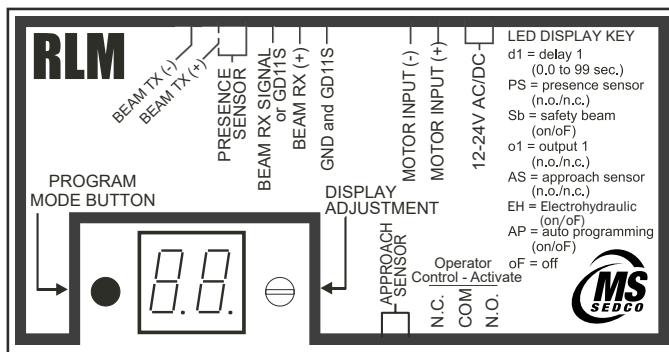

FIGURE 3—Operating and Programming Instructions



LED DISPLAY KEY

- (flashing) = Ready Mode
- Push **Program Mode Button**
- 1 Time = d1 0.0 - 99 seconds (Relay Lock Out Time)
- 2 Times = PS n.o. or n.c. (PS = Presence Sensor)
- 3 Times = Sb On or Off (Sb = Safety Beam)
- 4 Times = o1 n.o. or n.c. (o1 = Relay Output 1)
- 5 Times = AS n.o. or n.c. (AS = Approach Sensor)
- 6 Times = EH On or Off (EH = Electrohydraulic)
- 7 Times = AP On or Off (AP = Auto Program Mode for Relay Lockout Time)

Programming Instructions: Please read these instructions completely before proceeding.

- 1) Apply power to the RLM. The display will flash double bars (--). This indicates the RLM is ready to be programmed.



NOTICE: The RLM is equipped with an **Auto Program Mode** that will automatically program the necessary relay lockout time for the presence (safety) sensor (electromechanical operators only)—OR— you can manually select the relay lockout time you desire.

- 2) Press the **Program Mode Button** one time. The **LED display** will flash between d1 and 3.0. This is the factory setting relay lockout time of 3 seconds for the presence (safety) sensor. (a) If you want to use the **Auto Program Mode**, simply press the **Program Mode Button** again and proceed to step 3. (b) If you want to manually set the relay lockout time (mandatory with electrohydraulic operators), use a screwdriver to turn the **Display Adjustment Knob** clockwise to increase or counter-clockwise to decrease the time. Press the **Program Mode Button** to save the setting.
- 3) The **LED display** is now flashing between PS (Presence or Safety Sensor) and n.o. Select between n.o. (normally open) and n.c. (normally closed) by turning the **Display Adjustment Knob**, depending upon how the presence (safety) sensor relay output is wired. In most applications the output should be set to n.o. (factory setting). Press the **Program Mode Button** again to save the setting.
- 4) The **LED Display** is now flashing between Sb (Safety Beam) and oF (OFF). Select between OFF or ON by turning the **Display Adjustment Knob**, depending upon whether the RLM is controlling the safety beam. ON is the factory setting. Press the **Program Mode Button** again to save the setting.
- 5) The **LED Display** is now flashing between o1 (Output 1) and n.o. Output 1 is the output to the activate circuit on the operator control. Select between n.o. and n.c. by turning the **Display Adjustment Knob**, depending upon the desired relay output for Output 1. The activate circuit of most operator controls are n.o. (factory setting). Press the **Program Mode Button** to save the setting.
- 6) The **LED Display** is now flashing between AS (Approach Sensor) and n.o. Select between n.o. and n.c. by turning the **Display Adjustment Knob**, depending upon how your Approach Sensor relay output is wired. In most applications, the output should be set to n.o. (factory setting). Press the **Program Mode Button** again to save the setting.
- 7) The **LED Display** is now flashing EH (electrohydraulic) and oF (off). Select between ON and OFF by turning the **Display Adjustment Knob**, depending upon the type of door operator. EH=ON is for an Electrohydraulic and EH=OFF is for an Electromechanical operator. Press the **Program Mode Button** again to save the setting. Note: If electrohydraulic mode is selected, the AP (**Auto Program Mode**) will always be locked in the OFF position and the time set for d1 will be used. (See step 2).
- 8) The **LED Display** is now flashing AP (**Auto Program Mode**) and oF (OFF). Select between OFF and ON by turning the **Display Adjustment Knob**. When set to ON, the relay lockout time d1 is automatically programmed. When set to OFF, the relay lockout time d1 must be manually programmed (step 1). Press the **Program Mode Button** to save the setting.



NOTICE: Once the **Auto Program Mode** has been set to ON and saved, no other programming changes can be made without first removing and then reapplying power to the unit.

Auto Program Mode ON = LED Display is Blank. Clear the opening and activate the door. It will open and close one time. The **LED Display** will flash (- -). This indicates the relay lockout time has been successfully programmed. Activate the door again and the **LED Display** will count down the closing cycle time.

Auto Program Mode OFF = LED Display flashes (- -). This indicates the relay lockout time d1 was manually programmed. Clear the opening and activate the door. The **LED Display** will count down the closing cycle time selected in step 1.

RLM Programming is Complete.



Troubleshooting:

- Problem:** When I activate the door it does not open and the LED Display Flashes PS when the presence (safety) sensor is not activated.
Solution: The presence (safety) sensor is not programmed correctly (Step 3). Make sure the wiring of the presence (safety) sensor relay output matches the RLM programming of either n.o. or n.c.
- Problem:** When I activate the door it does not open and the LED Display flashes Sb when the Safety Beam is not activated.
Solution: The Safety Beam is not programmed correctly (Step 4). If no Safety Beams are used, make sure Sb = OFF.
- Problem:** I am using dry contact safety beams instead of the RLM-SB safety beams.
Solution: Dry contact safety beams wire differently. Refer to Page 1, Section 2—Basic Installation.
- Problem:** When I apply power to the door it immediately goes to hold open.
Solution 1: Output o1 is programmed incorrectly (Step 5). Make sure program setting matches the activate circuit on the operator control of either n.o. or n.c.
and/or
Solution 2: The Approach Sensor is not programmed correctly (Step 6). Make sure the wiring of the approach sensor relay output matches the RLM programming of either n.o. or n.c.
- Problem:** I set the Auto Program Mode ON and activated the door one time to program the door's closing time. Now the door will not reopen when I activate it.
Solution: The motor input wires connected to the RLM are polarity sensitive. Remove power to the RLM, reverse the motor input wire connections and reapply power. Refer to Figure 3 and reprogram the device.



WARNING: You must first remove power to the RLM BEFORE reversing the motor wire connections & then reapply power or the device will malfunction.

- Problem:** I set the Auto Program Mode OFF and activated the door. Now the door keeps reactivating by itself and is standing open.
Solution: The motor input wires connected to the RLM are polarity sensitive. Prop the door open first then remove power to the RLM, reverse the motor input wire connections and reapply power. Refer to Figure 3 and reprogram the device.



WARNING: Removing power to the RLM will cause the door to close. If the door is in the open position when power is removed, be sure to prop it open.

- Problem:** The timer countdown begins during the opening cycle.
Solution: The electrohydraulic (EH) setting is incorrect (Step 7).
EH=ON=Electrohydraulic operators.
EH=OFF=Electromechanical operators.