

# 216TX

## Active Infrared Wireless Touchless Switch

## INSTALLATION INSTRUCTIONS

### Section 1

#### General Description

The 216TX Wireless Touchless switches are active infrared devices designed for hands-free activation of automatic door operators or other access control products. The 216TX switch assembly includes the 1020 mounting box and transmitter for wall mount applications. The wireless transmitter features ClearPath™ technology for use with most 300 MHz, 390 MHz, and ClearPath™ receivers.

### Section 2

#### Basic Installation

- 1) Remove the 1/4-20 screw located in the bottom of the frame and separate the back plate from the frame (Fig. 1). Secure the back plate in its intended location with at least 2 screws.



**WARNING:** Mounting screws must be flush with the back plate to ensure proper assembly.

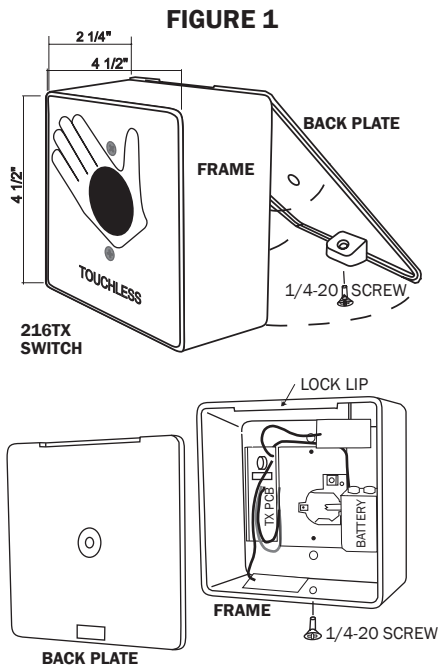

- 2) **SELECT FREQUENCY:** Select the desired frequency, via the 3-position slide switch, on the transmitter circuit board (Fig. 2). HDRC™ is factory setting.
- 3) **SELECT SECURITY CODE:** Program the desired security code, via the 12 dip switches, on the transmitter circuit board (Fig. 2).

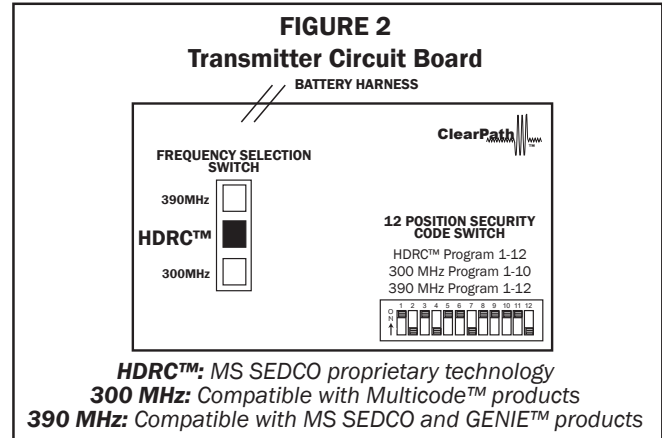

**HDRC™:** MS SEDCO proprietary technology  
**300 MHz:** Compatible with Multicode™ products  
**390 MHz:** Compatible with MS SEDCO and GENIE™ products

- 4) Insert the coin cell battery (provided) with the plus (+) side facing up (visible when inserted).



**NOTICE:** This device complies with Part 15 of the FCC rules. Operation of this device is subject to the following two conditions: 1) This device may not cause harmful interference and 2) This device must accept any interference received, including interference that may cause undesired operation. Any changes or modifications not expressly approved by MS SEDCO could void the user's authority to operate this equipment.

- 5) Adjust range via potentiometer on the back of the switch assembly (Fig. 3).

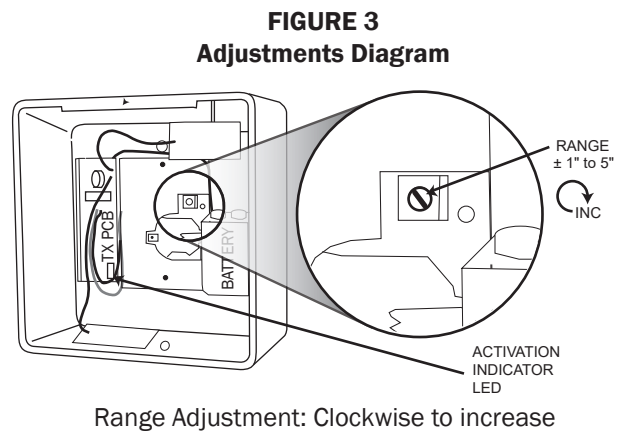

- 6) Attach the mounting box frame to the back plate already mounted in its intended location (step 1) by placing the lock lip of the frame over the top of the back plate, pushing it down in a hinge-like motion (Fig. 1).
- 7) Secure the mounting box frame to its back plate at the under-side with the 1/4-20 screw supplied (Fig. 1).

# 216TX

## Active Infrared Wireless Touchless Switch

## INSTALLATION INSTRUCTIONS

### Section 3

#### Warranty

MS SEDCO guarantees this product to be free from manufacturing defects for 1 year from date of shipment from our factory. If during the first year, our product fails to operate and has not been tampered with or abused, the unit can be returned prepaid to factory and it will be repaired free of charge. After 1 year, the unit will be repaired for a nominal service charge. **This limited warranty is in lieu of all other warranties expressed or limited, including any implied warranty of merchantability, and no representative or person is authorized to assume for MS SEDCO any other liability in connection with the sales of our products. All warranties are limited to the duration of this written warranty. In no event shall MS SEDCO be liable for any special, incidental, consequential or other damages arising from the claimed breach of warranty as to its products or services.**

**Questions? Call us at 1-317-842-2545 or visit us online at [www.mssedco.com](http://www.mssedco.com).**

